

Junior Phenolic Folding Shower Seats

Rectangle with Legs

Configuration:

63 Series
with legs

Application Use:

Architectural

Commercial

Institutional

Residential

Specifications

Folding shower seat manufactured by Elcoma from 1" (25mm) diameter, 18 gauge and 1.25" x 1.25" (32mm x 32mm), 16 gauge, type 304 stainless steel tubing with #4 satin finish. Wall mount brackets shall be 12 gauge type 304 stainless steel. Solid Phenolic seat shall be 1/2" (13mm) thick and shall be fire and mildew resistant. Shower Seat shall comply with all applicable federal, provincial and local building safety codes.

White shown, also available in woodgrain.



Custom sizes are available to suit special requirements.

16" x 16" (406mm x 406mm)	White	Model # 63-PH1451601WLEG
16" x 16" (406mm x 406mm)	Woodgrain	Model # 63-PH1451615WLEG
18" x 16" (457mm x 406mm)	White	Model # 63-PH1451801WLEG
18" x 16" (457mm x 406mm)	Woodgrain	Model # 63-PH1451815WLEG

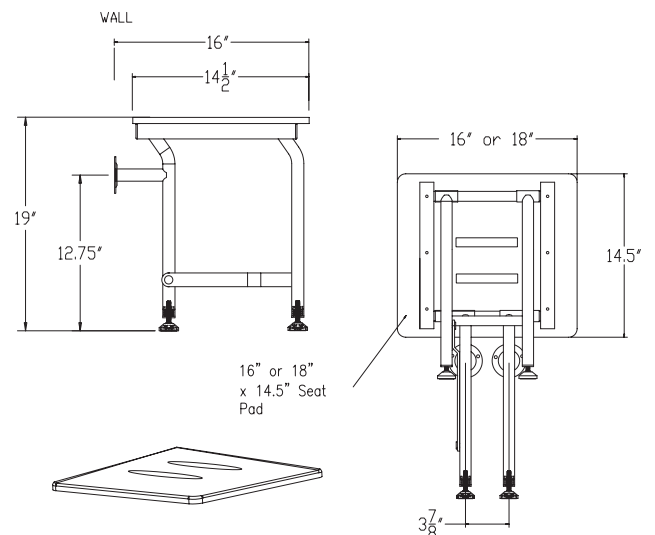

Elcoma Shower Seats have been designed and tested to withstand 400lbs. (181kgs) of load when properly installed.* This exceeds HUD, FHA, VA, ADA, ANSI and other federal, provincial and local codes.

*Shower seats can only be as strong as what they are mounted to. It is imperative when installing any shower seat to consult with a qualified contractor to insure you have sufficient backing.